

Typical Features	
◆	Fixed input voltage, Isolated & unregulated, Output power 1W
◆	Efficiency up to 86% (Typ.)
◆	Mini size SIP packaging
◆	Isolation Voltage 1500VDC
◆	Operating Temperature from -40°C to +105°C
◆	Plastic Case, flame class UL94 V-0



**Test Condition:** Unless otherwise specified, all parameter values had been tested at nominal input voltage, pure resistive rated load, and at room temperature 25°C.

### Application Field

*This series of products can be widely used in the fields of instrument, communication, pure digital circuit, general low frequency analog circuit, relay drive circuit, data exchange circuit, etc.*

### Typical Product List

Certificate	Part No.	Input Voltage Range (VDC)		Output Voltage/Current (Vo/Io)		Input Current (mA) Typ. Nominal Voltage		Max. Capacitive Load uF	Ripple & Noise (20MHz) Max/Typ. mVp-p	Efficiency (%) @full load/nom. voltage	
		Nom.	Range	Vo (VDC)	Io(mA) Max/Min	Full Load	No Load			Min	Typ.
-	FN1-3V3S3V3AN	3.3	2.97 - 3.63	3.3	303/30	370	8	2400	75/40	74	76
-	FN1-3V3S05AN			5	200/20	358	8	2400	75/40	81	83
-	FN1-3V3S12AN			12	83/9	340	10	560	75/40	83	85
-	FN1-3V3S15AN			15	67/7	345	20	560	75/40	81	83
-	FN1-3V3S24AN			24	42/5	360	25	220	100/80	81	83
-	FN1-05S3V3AN	5	4.5 - 5.5	3.3	303/30	250	8	2400	75/40	78	80
UL	FN1-05S05AN			5	200/20	225	8	2400	75/40	83	85
-	FN1-05S09AN			9	111/12	227	10	1000	75/40	83	85
CE	FN1-05S12AN			12	83/9	220	10	560	75/40	83	85
CE	FN1-05S15AN			15	67/7	220	15	560	75/40	83	85
-	FN1-05S24AN			24	42/5	266	18	220	100/80	82	84
-	FN1-09S09AN	9	8.1-9.9	9	111/12	128	10	560	75/40	82	84
-	FN1-12S3V3AN	12	10.8 - 13.2	3.3	303/30	98	10	2400	75/40	75	77
UL/CB	FN1-12S05AN			5	200/20	96	10	2400	75/40	84	86
-	FN1-12S09AN			9	111/12	92	10	1000	75/40	84	86
UL/CE/CB	FN1-12S12AN			12	83/9	90	10	560	75/40	84	86
-	FN1-12S15AN			15	67/7	90	10	560	75/40	84	86

-	FN1-12S24AN			24	42/5	92	10	220	100/80	83	85
-	FN1-15S05AN	15	13.5 - 16.5	5	200/20	78	10	2400	75/40	83	85
-	FN1-15S12AN			12	83/9	76	10	1000	75/40	84	86
-	FN1-15S15AN			15	67/7	76	10	560	75/40	83	85
-	FN1-15S24AN			24	42/5	75	10	470	100/80	83	85
-	FN1-24S3V3AN			24	21.6 - 26.4	3.3	303/30	52	8	2400	75/40
-	FN1-24S05AN	5	200/20			47	8	2400	75/40	82	84
-	FN1-24S09AN	9	111/12			48	8	1000	75/40	83	85
-	FN1-24S12AN	12	83/9			48	8	560	75/40	84	86
-	FN1-24S15AN	15	67/7			48	8	560	75/40	83	85
-	FN1-24S24AN	24	42/5			49	8	220	100/80	83	85

Note: The ripple & noise are tested by the twisted pair method.

**Input Specifications**

Item	Operating Condition	Min.	Typ.	Max.	Unit
Input Inrush Voltage (1Sec max.)	3.3Vdc Input	-0.7	-	7	VDC
	5Vdc Input	-0.7	-	9	
	9Vdc Input	-0.7	-	12	
	12Vdc Input	-0.7	-	18	
	15Vdc Input	-0.7	-	21	
	24Vdc Input	-0.7	-	30	
Input Filter	Capacitor Filter				
Hot Plug	Unavailable				

**Output Specifications**

Item	Operating Condition	Min.	Typ.	Max.	Unit
Output Power		0.1	--	1	W
Output Voltage Accuracy	Please refer to the output voltage deviation curve (Figure 1)				
Load Regulation	10% ~ 100% load	3.3Vdc output	--	15	%
		Other output	--	10	
Line Voltage Regulation	Input Voltage Change ±1%	3.3Vdc output	--	1.5	--
		Other output	--	1.2	
Temperature Drift Coefficient	100% Load	--	--	±0.03	%/°C
Short Circuit Protection	Continuous, self-recovery				

**General Specifications**

Item	Operating Condition	Min.	Typ.	Max.	Unit
Switching Frequency	Nominal input voltage, full load	--	260	--	KHz
Operating Temperature	Refer to the Temperature Derating Curve (Figure 2)	-40	--	105	°C
Storage Temperature		-55	--	+125	
Case temperature rise	Ta=25°C	--	30°	--	
Pin soldering temperature	1.5mm from the case, 10S	--	--	300	
Relative Humidity	No condensing	5	--	95	%RH
Isolation Voltage	I/P-O/P, test 1 minute, leakage current <1mA	1500	--	--	VDC
Insulation Resistance	I/P-O/P, @ 500VDC	1000	--	--	MΩ
Isolation Capacitor	Input/Output, 100KHz/0.1V	--	20	--	pF
Vibration		10-150Hz, 5G, 30 Min. along X, Y and Z			
MTBF	MIL-HDBK-217F@25°C	3500	--	--	K hours
Case Material	Plastic in Black, flame class UL94-V0				
Unit Weight	1.4g (Typ.)				
Cooling Method	Natural air				
Packing	Tube size (525x18x10mm)	43PCS/Tube			
	Carton size (542x110x155mm)	3440PCS/Carton (Total 80 Tubes)			
Dimensions	L x W x H	11.50 × 6.00 × 10.10 mm		0.453 × 0.236 × 0.398 inch	

**EMC Performance**

EMI	CE	CISPR32/EN55032 CLASS B (with Recommended EMC circuit)
	RE	CISPR32/EN55032 CLASS B (with Recommended EMC circuit)
EMS	ESD	IEC/EN61000-4-2 Air±8kV, Contact±6kV perf.Criteria B

**Packing Dimension**

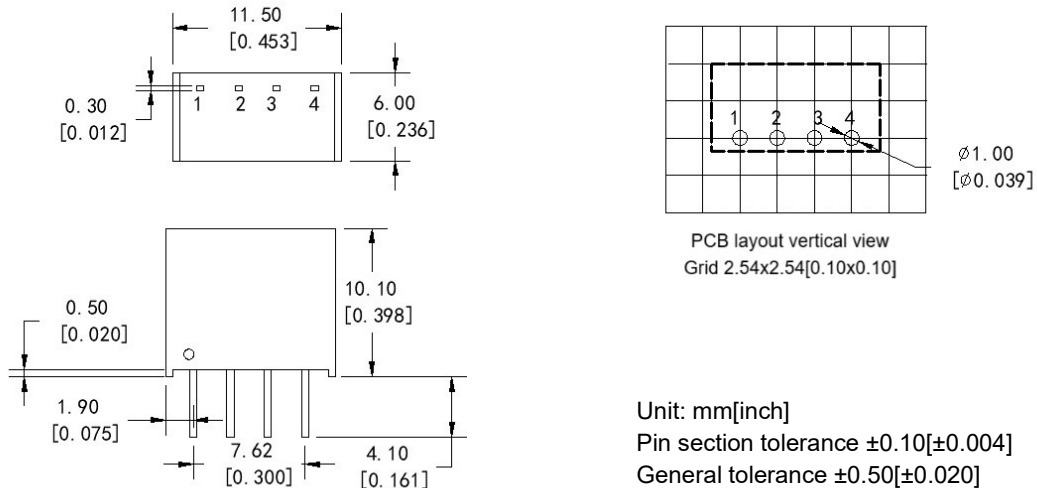

**Pin Function definition**

Pin No.	1	2	3	4
Single(S)	GND (input)	+Vin	-Vout	+Vout

Note - Please take the pin definition on the product label as the right one if there is any difference between the data sheet and the one printed on the product label.

**Ripple & Noise Test Instruction (Twisted Pair Method, 20MHZ bandwidth)**

1) The Ripple & noise test need 12# twisted pair cables, an oscilloscope which bandwidth should be set to 20MHz, 0.1uF polypropylene capacitor and 10uF high-frequency low-resistance electrolytic capacitor are connected in parallel with the probes (100M bandwidth). The oscilloscope should be set at the Sample Mode.

2) The test diagram is shown on the right. The converter output connects to the electronic load by the jig with cables which size should be defined according to the output current value. The twisted pair (length 30cm±2 cm) should be connected in parallel with the load, the location is as close as possible to the output pins or terminals. The test can be started after input power on.

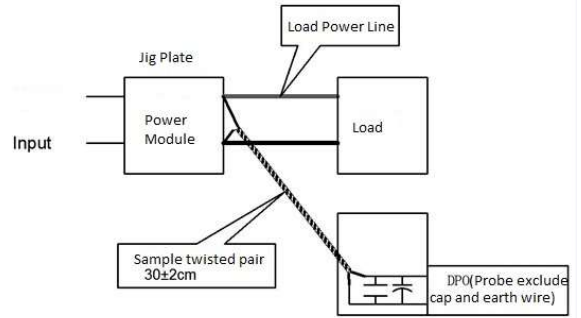

**Product Performance Curves**

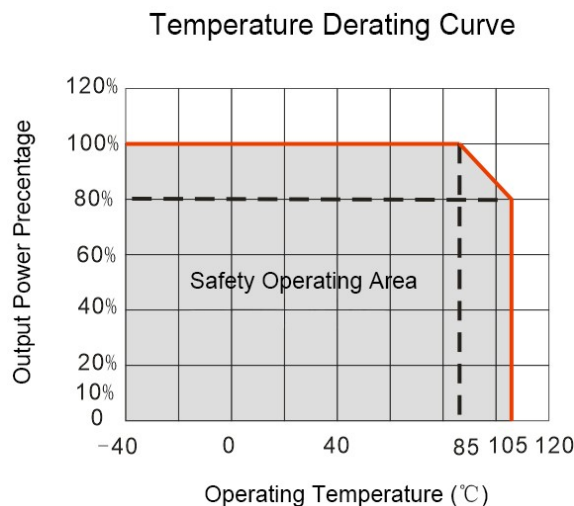
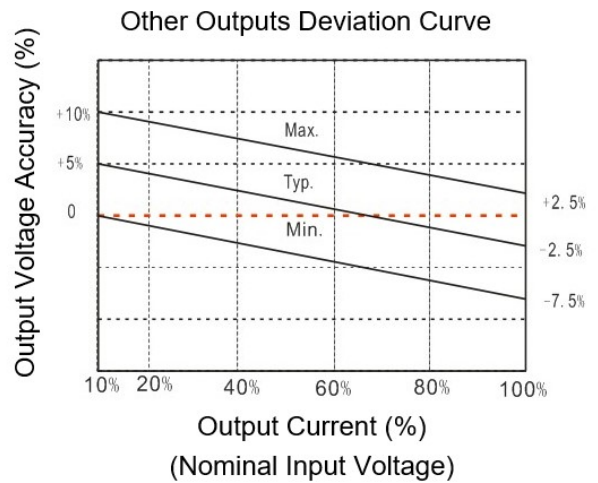
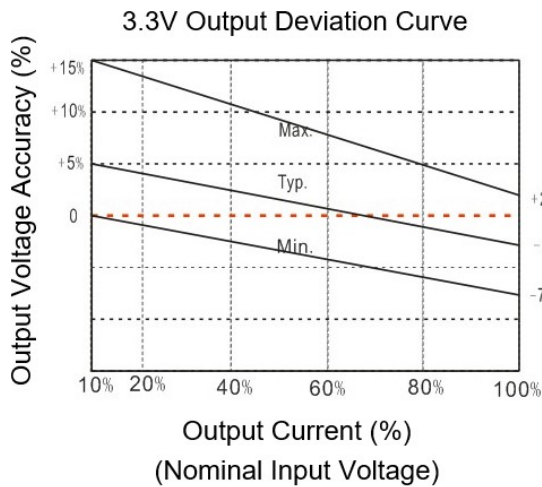

**Recommended Circuits for Application**

**1. Requirement for Output load**

The maximum capacitive load was tested at the rated full load. The converter may not start or be damaged if the output capacitors exceed this value.

**2. Typical application circuit**

To ensure effectively decrease the input and output ripple and noise, a capacitor filter can be connected at the input and output, the application circuit is shown in the figure below. The suitable filter capacitors should be chosen as the recommended capacitive load values in Table 1. The converter could not start if the capacitance is too big.

**Single**



**Dual**

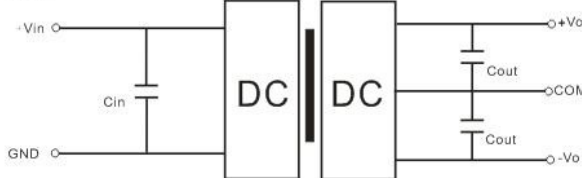

**Recommended capacitive load value (Table 1)**

Vin (Vdc)	Cin	Single Vout (Vdc)	Cout (μF)	Dual Vout (Vdc)	Cout (μF)
5	10 μF/16V	3.3	10 μF/16V	±3.3	4.7 μF/16V
12	2.2 μF/25V	5	10 μF/16V	±5	4.7 μF/16V
15	2.2 μF/25V	9	2.2 μF/25V	±9	2.2 μF/25V
24	1 μF/50V	12	2.2 μF/25V	±12	1 μF/25V
--	--	15	1 μF/25V	±15	1 μF/16V
--	--	24	1 μF/50V	±24	0.47 μF/50V

**3. Recommended EMC Circuit**

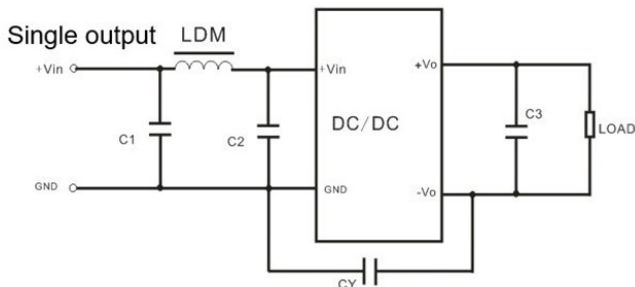

Input voltage		5VDC	12/15/24VDC
EMI	C1/C2	4.7 μF/16V	4.7 μF/50V
	CY	270pF/2KV	270pF/2KV
	C3	Refer to Cout in Table 1	
	LDM	6.8 μH	6.8 μH

**4. Output voltage regulation and overvoltage protection**

The simple solution to achieve the output regulated voltage, over voltage and over current protections is to connect a linear regulator with overheat protection at input or output, and a capacitor filter connected in parallel as below circuit. Filter capacitive value recommended see table 1, Linear regulator should be chosen according to the actual voltage & current for operating. Or Aipu NW series products are recommended instead.

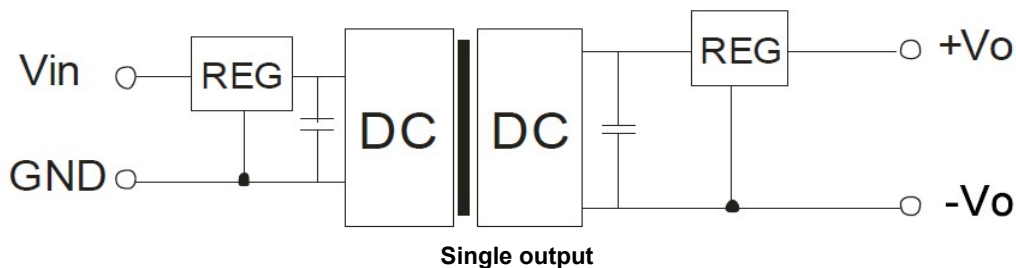

**Application Notice**

1. This series of converters should not be used in parallel, and they do not support hot-plugging.
2. The product performance in this datasheet cannot be guaranteed if it works at a lower load than the minimum load condition.
3. All values or indicators in this datasheet had been tested based on Aipupower test specifications.

**Guangzhou Aipu Electron Technology Co., Ltd**

Address: Building 4, HEDY Park, No.63, Punan Road, Huangpu Dist, Guangzhou, China.

Tel: 86-20-84206763 Fax: 86-20-84206762 HOTLINE: 400-889-8821

E-mail: sales@aipu-elec.com Website: <https://www.aipupower.com>